



OPTIONS



VERSIONS

Type	Current per Winding A	Holding Torque Ncm	Resistance per Winding Ohm	Inductance per Winding mH	Rotor Inertia gcm ²	Weight kg	Length „A“ mm
ST6318F1004-A	1	6	3.8	2	16	0.095	9.6

ORDER IDENTIFIER

ST6318F1004-A

DIMENSIONS (IN MM)

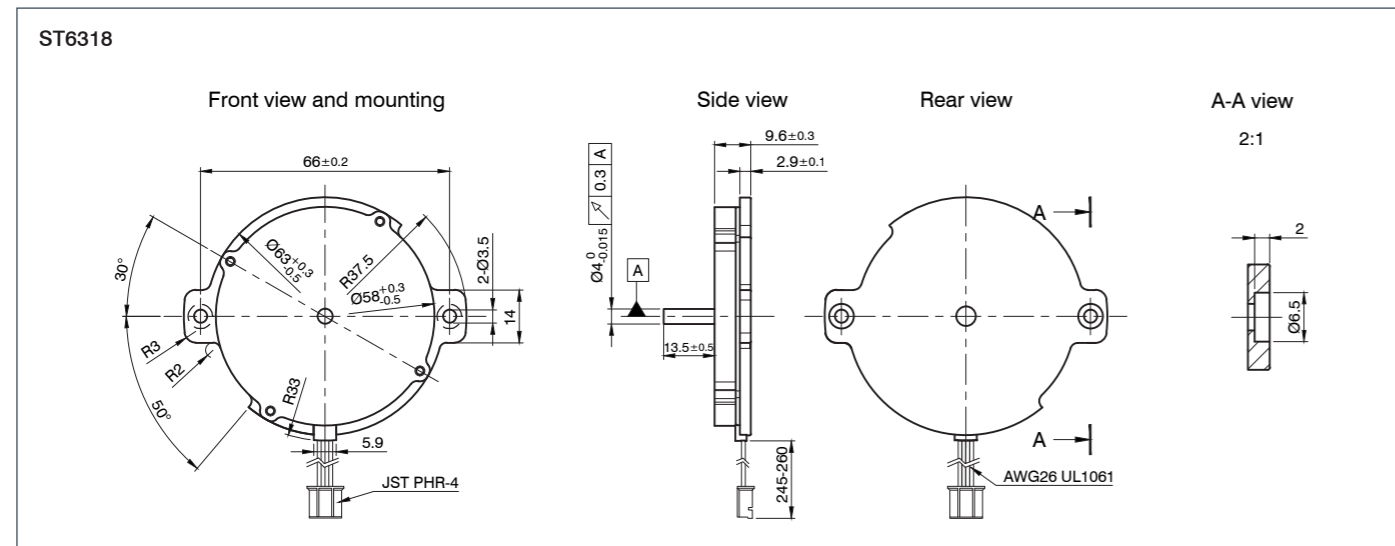

TORQUE CURVES

